

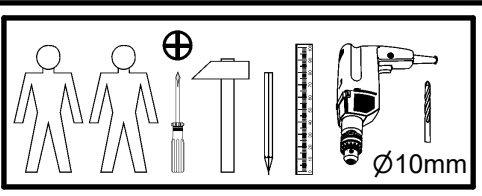

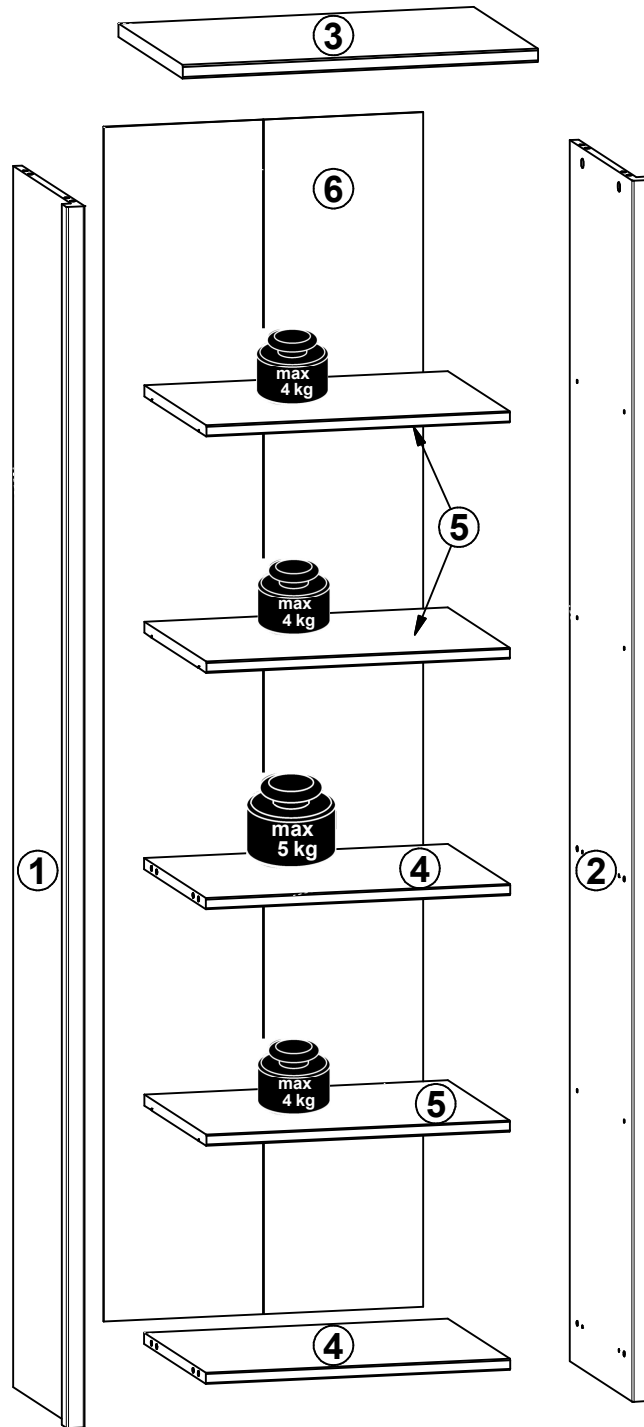
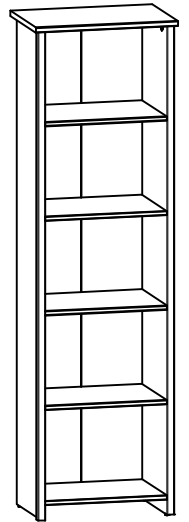

A

PORTO

S322-REG/60

A	B	C	D
1	S322-136	1968	384
2	S322-137	1968	384
3	S322-204	584	395
4	S322-304	500	381
5	S322-320	499	381
6	S322-911	1925	525

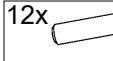

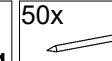
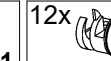
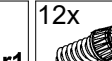
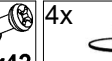
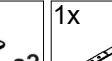
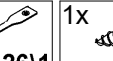
- 
 12x $\varnothing 5 \times 17$ mm **d1**
- 
 12x $\varnothing 8 \times 30$ mm **f1**
- 
 4x **k1**
- 
 50x **l1**
- 
 12x $\varnothing 15 \times 12$ mm #16 **r1**
- 
 12x 20/11 **r2**
- 
 4x $\varnothing 16$ **s2**
- 
 1x **n26/1**
- 
 1x $\varnothing 3.5 \times 16$ mm **p38**

1

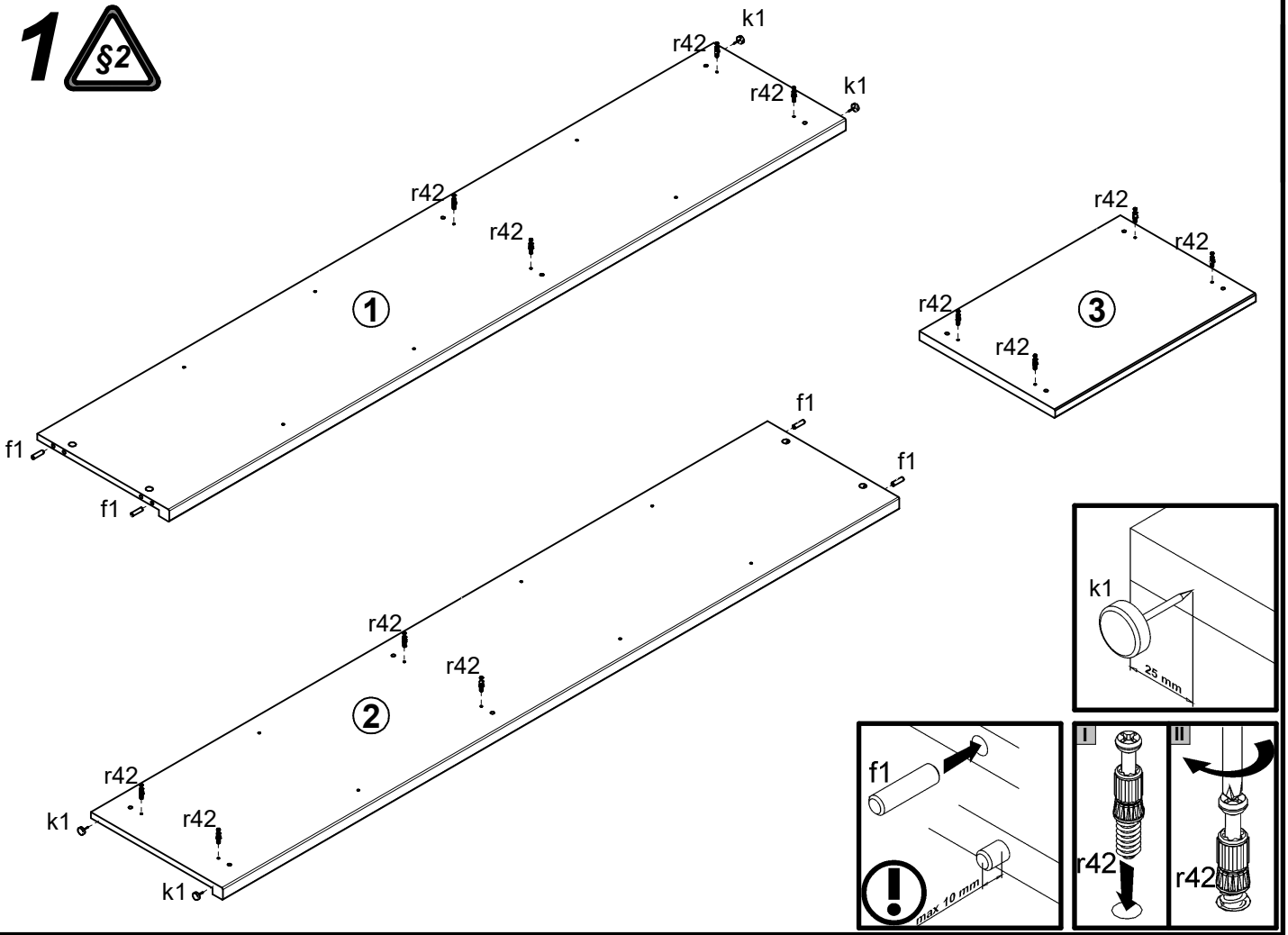

2

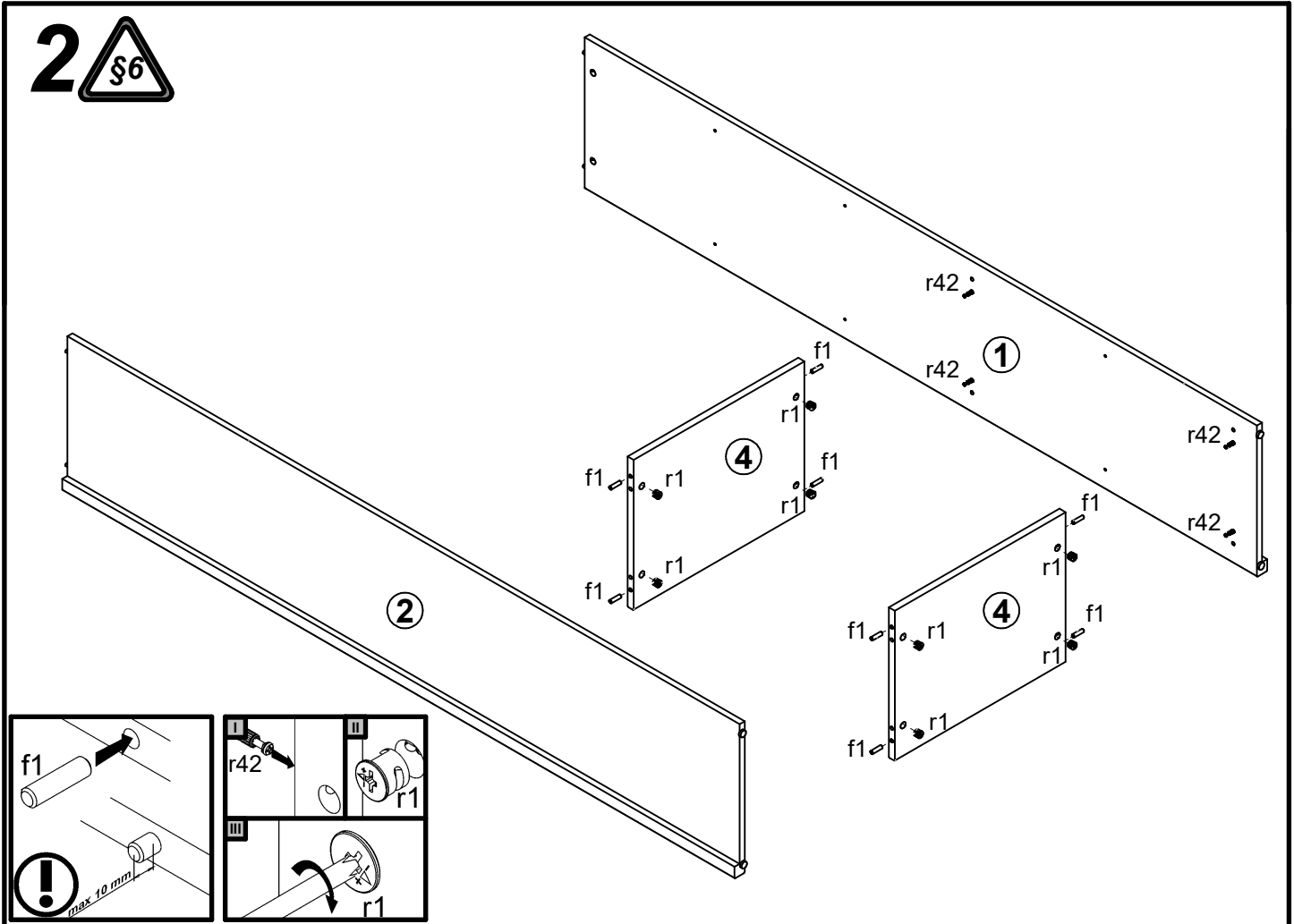

3

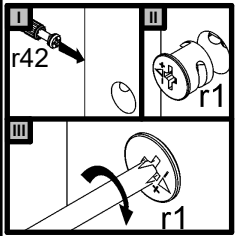
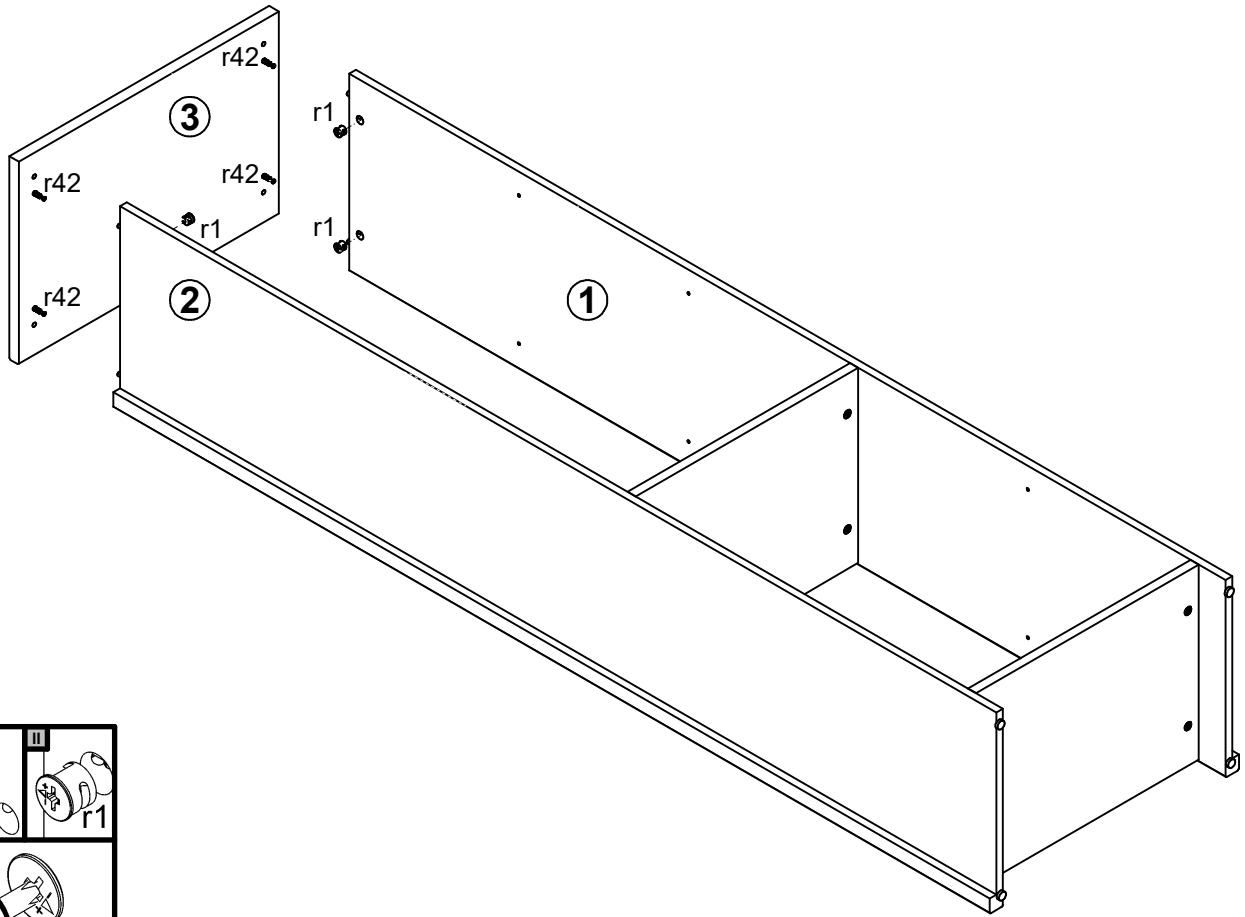

4

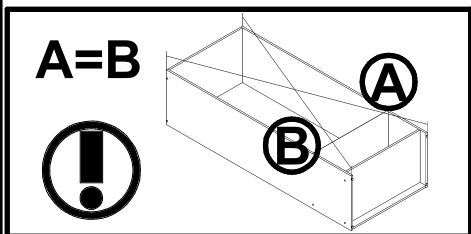
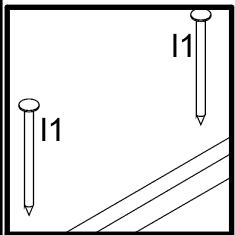
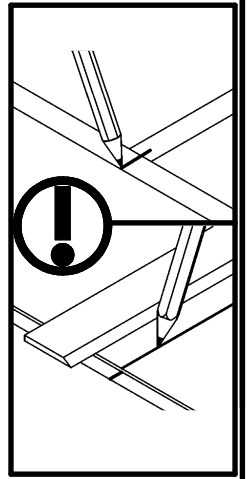
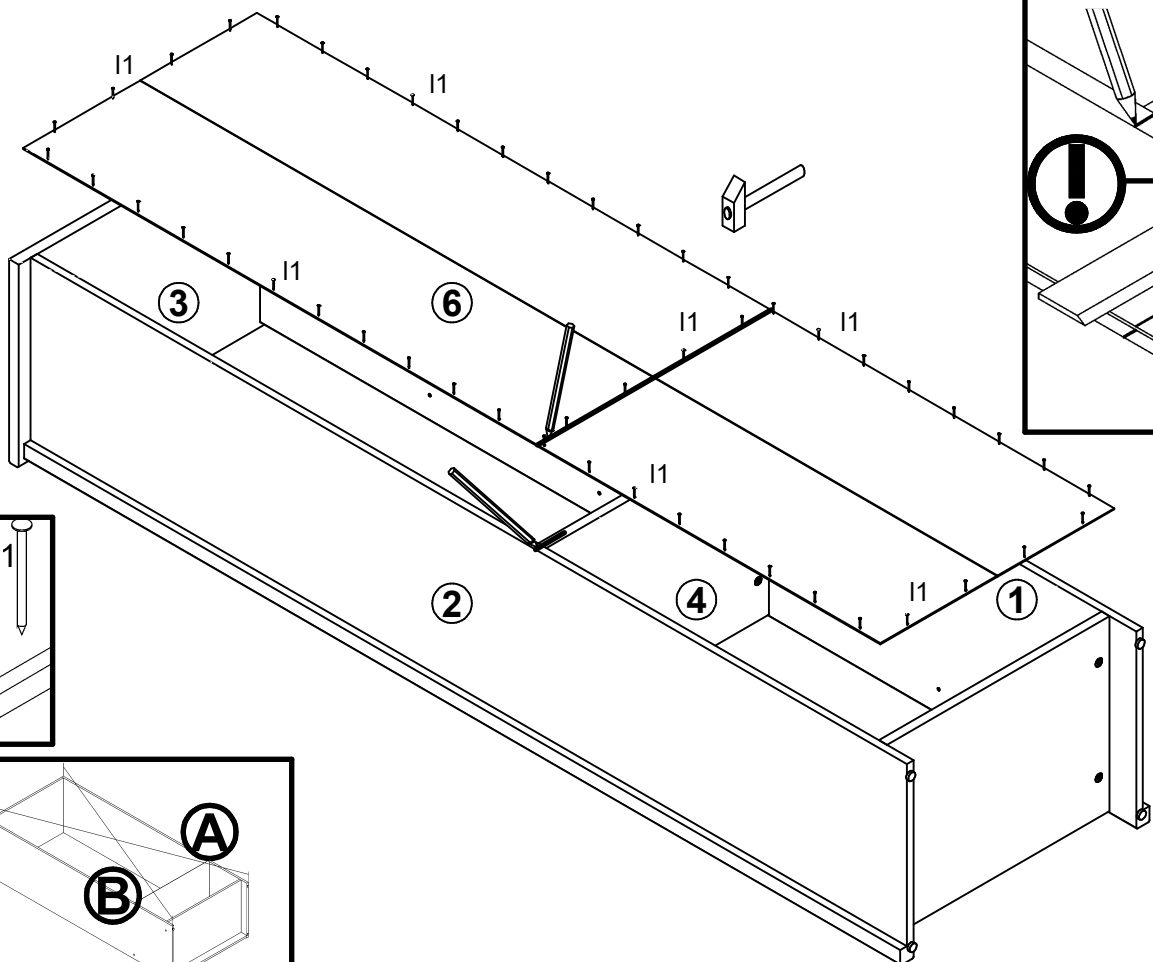

5

